

EIXO/SHAFT	
PADRÃO/STANDARD	X
OPCIONAL/OPTIONAL	
ESPECIAL/SPECIAL	

Dimensões em polegada
Dimensions in inches

THIS IS AN UPDATED REVISION, THE PREVIOUS ONE MUST BE DISREGARDED.

A
B
C
D
E

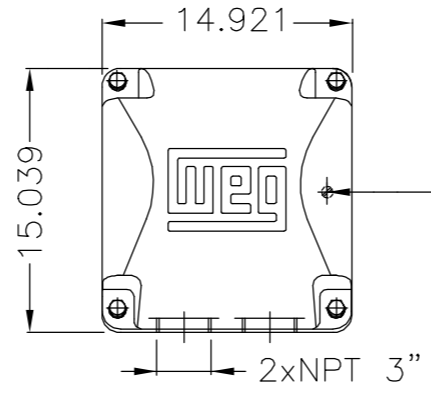
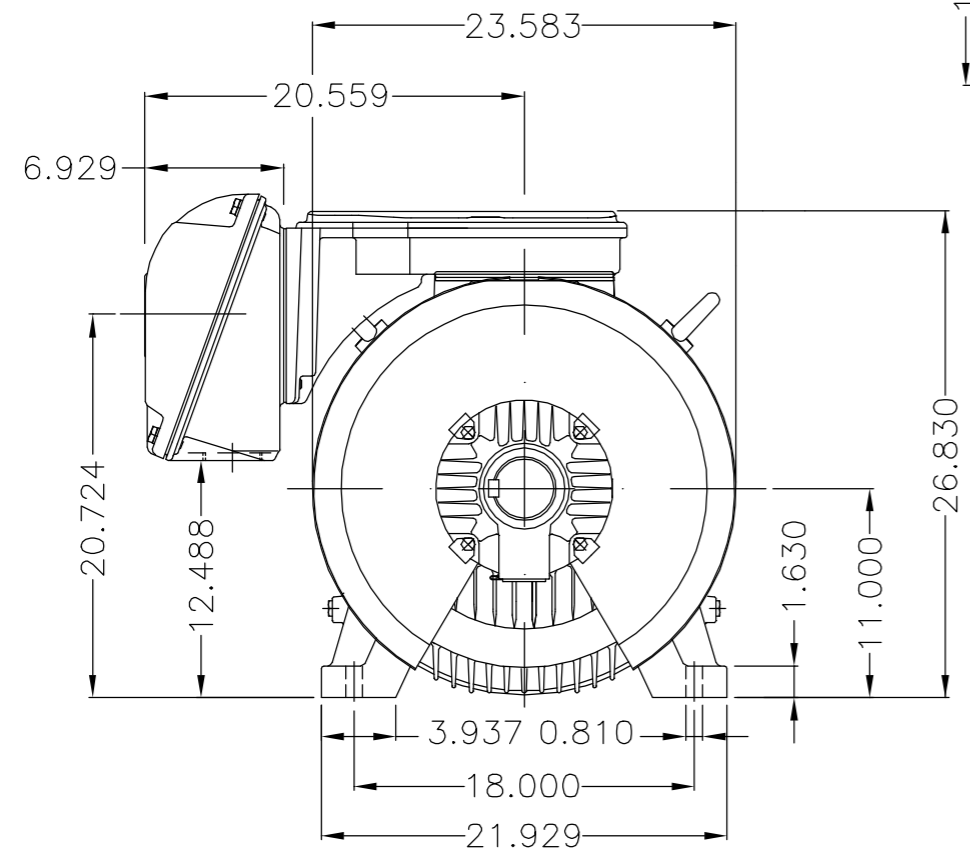

Main terminal box

Grounding for leads 35-70 mm² / 1-2/0 AWG

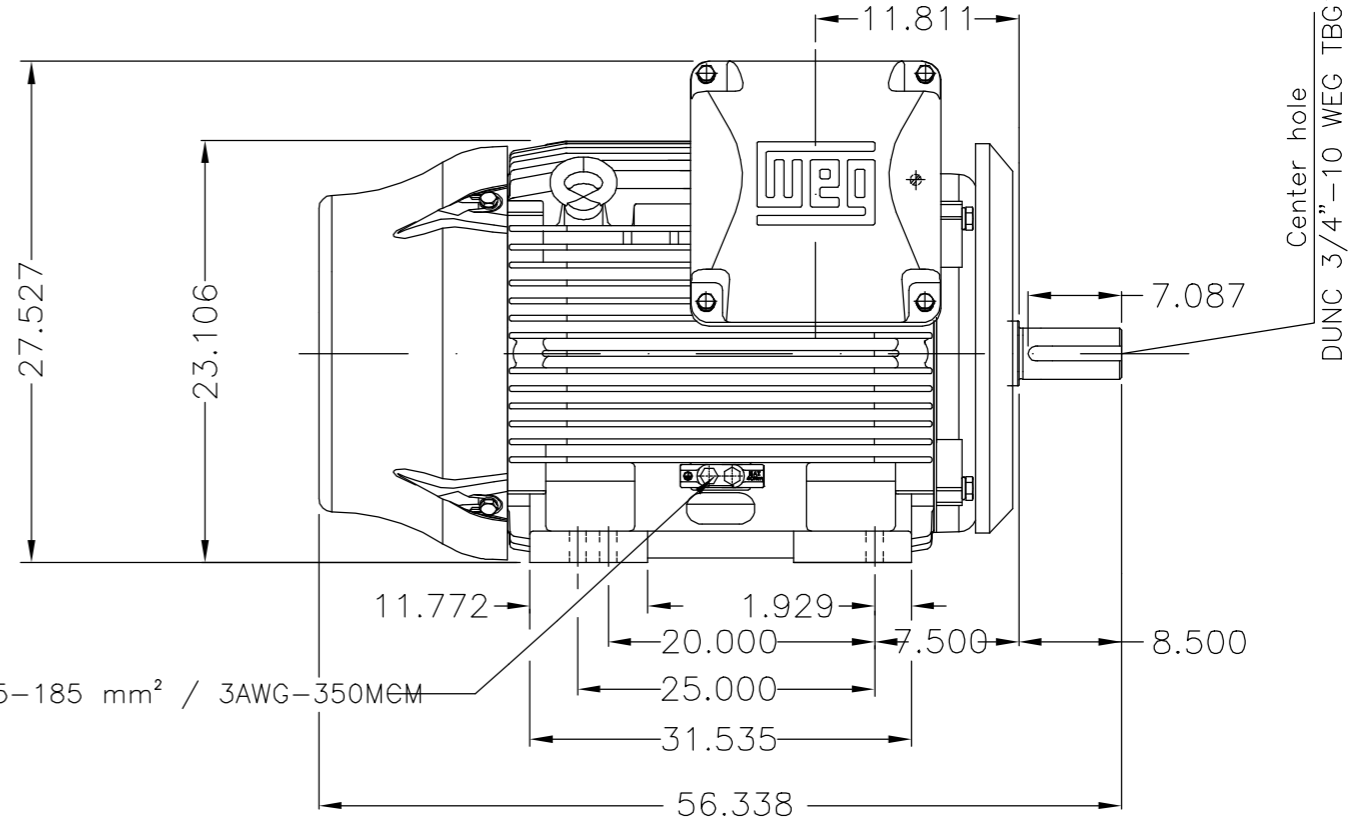

Grounding for leads 25-185 mm² / 3AWG-350MEM

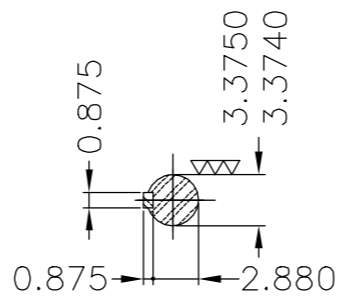

DE Shaft End

Defletor de ar dianteiro / Drive-End Air Deflector						
Dispositivo de travamento de eixo / Shaft locking device						
Rolamento dianteiro de rolos / DE roller bearing						
Cor RAL 5009 / Color RAL 5009						
Plano de pintura 203A / Painting plan 203A						
Forma construtiva B3D / Mounting B3R(D)						
V.J. PAMENSKY CANADA INC.						

OV: 4853577

500001472717		ALT. CONFORME CLAIM 415104836	FRANCINES	CLEBERP	CLEBERP	03.07.2018	01
500001466603		DOCUMENTO NOVO	ERIC	FRANCINES	FRANCINES	03.07.2018	00
ECM	LOC	SUMMARY OF MODIFICATIONS	EXECUTED	CHECKED	RELEASED	DATE	VER
EXECUTED	ERIC	THREE PHASE W22 MOTOR - NEMA PREMIUM EFF FRAME 447/9T IP55 TEFC			10005837378		
CHECKED	FRANCINES				000 01		
RELEASED	FRANCINES				SHEET 01 / 01		
REL DT	03.07.2018	WMO Jaragua do Sul	Product Engineering				

300 HP 06 Poles 60Hz

A



UNCONTROLLED COPY RELEASED ZME A3