

EIXO/SHAFT	
PADRÃO/STANDARD	X
OPCIONAL/OPTIONAL	
ESPECIAL/SPECIAL	

Dimensões em polegada
Dimensions in inches

THIS IS AN UPDATED REVISION, THE PREVIOUS ONE MUST BE DISREGARDED.

A
B
C
D
E

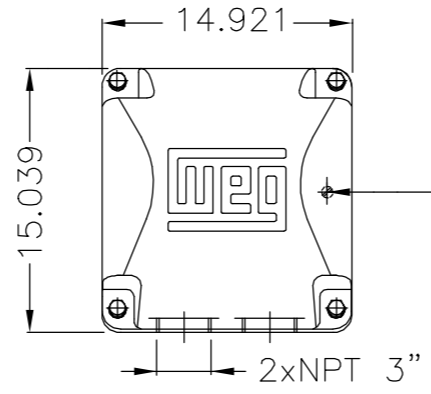
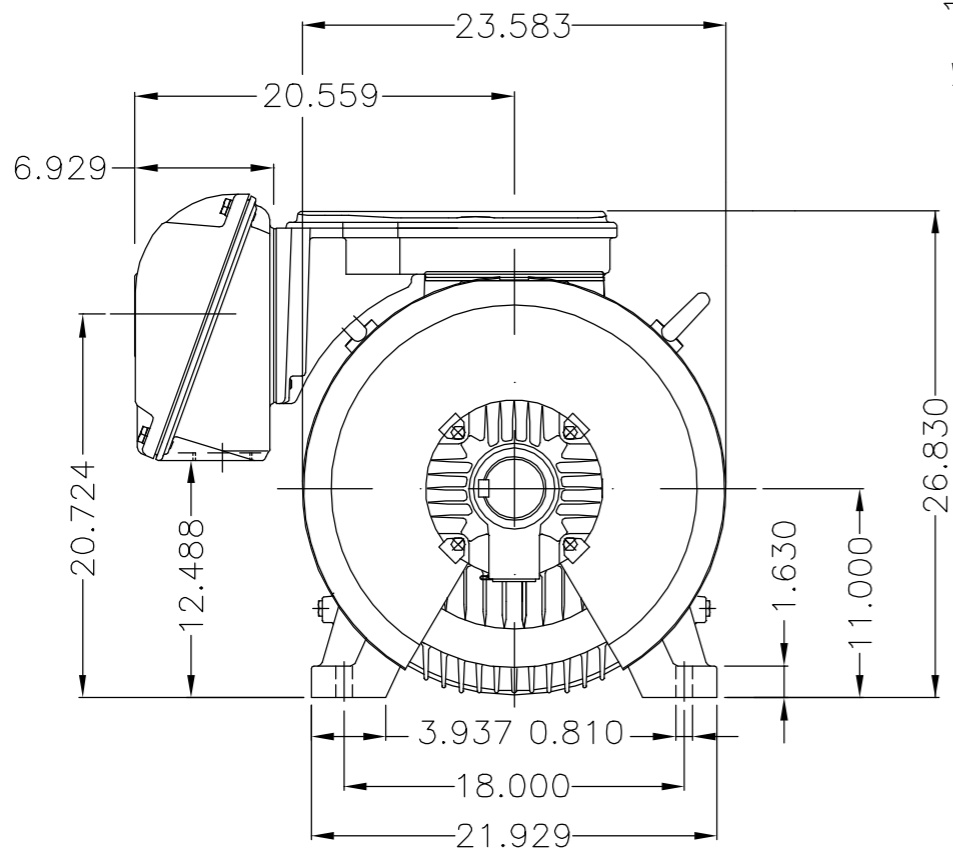

Main terminal box

Grounding for leads 35-70 mm² / 1-2/0 AWG

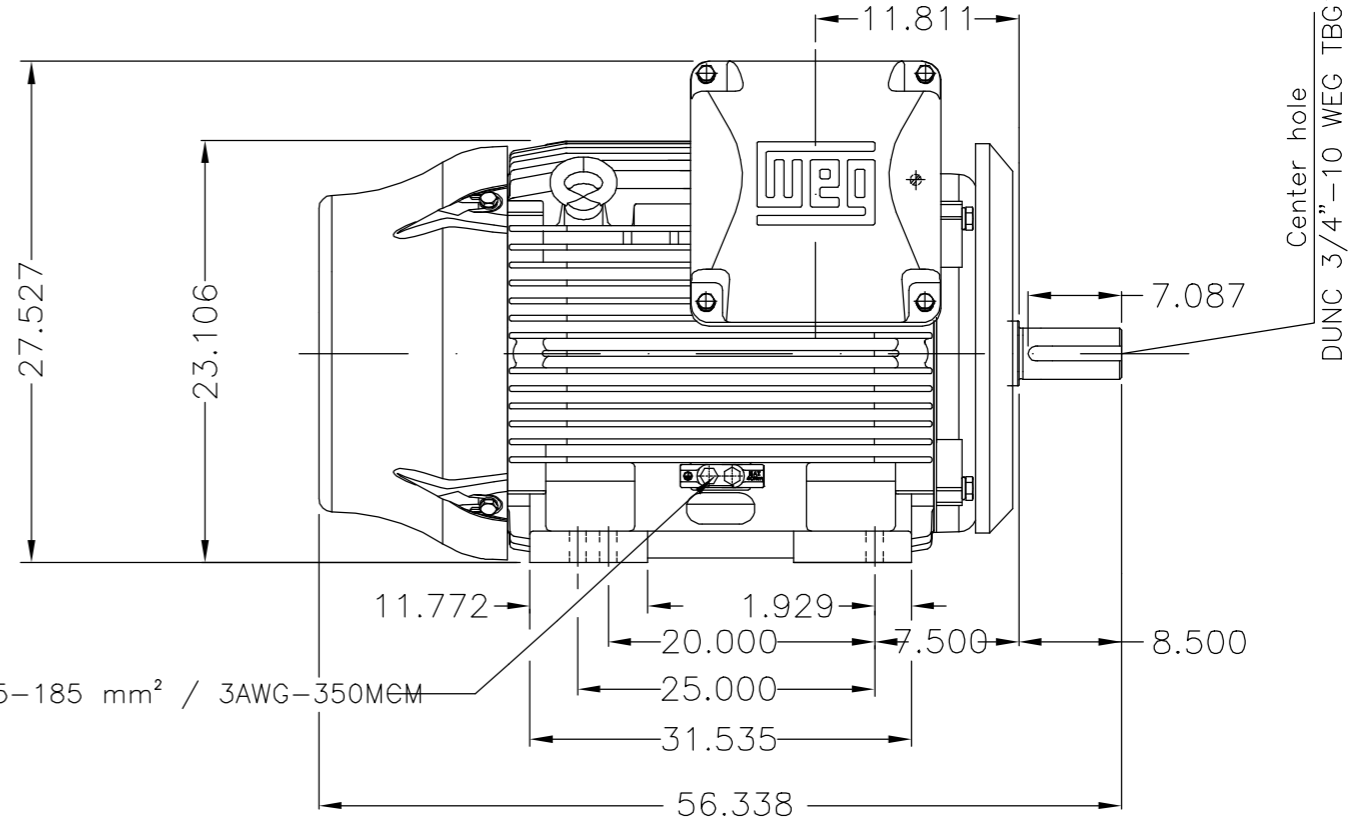

Grounding for leads 25-185 mm² / 3AWG-350MEM

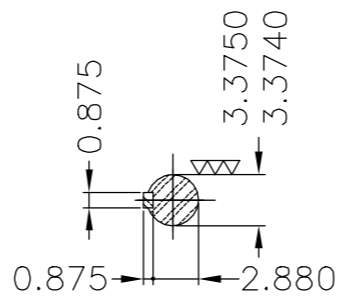

DE Shaft End

Defletor de ar dianteiro / Drive-End Air Deflector
Rolamento dianteiro de rolos / DE roller bearing
Dispositivo de travamento de eixo / Shaft locking device
Tampão liso de plástico / Plastic flat plug
Cor RAL 5009 / Color RAL 5009
Plano de pintura 203A / Painting plan 203A
Forma construtiva B3D / Mounting B3R(D)
V.J. PAMENSKY CANADA INC.

OV: 4854509

500001472717	ALT. CONFORME CLAIM 415104836	FRANCINES	CLEBERP	CLEBERP	03.07.2018	01		
500001466603	DOCUMENTO NOVO	ERIC	FRANCINES	FRANCINES	03.07.2018	00		
ECM	LOC	SUMMARY OF MODIFICATIONS		EXECUTED	CHECKED	RELEASED	DATE	VER
EXECUTED	ERIC		THREE PHASE W22 MOTOR - NEMA PREMIUM EFF		10005837376			
CHECKED	FRANCINES		FRAME 447/9T IP55 TEFC		000	01		
RELEASED	FRANCINES							
REL DT	03.07.2018	WMO	Jaragua do Sul	Product Engineering	SHEET	01 / 01		

300 HP 04 Poles 60Hz

A